

# GRABO

## GRABO® V2 HEAVY LIFTING MADE EASY

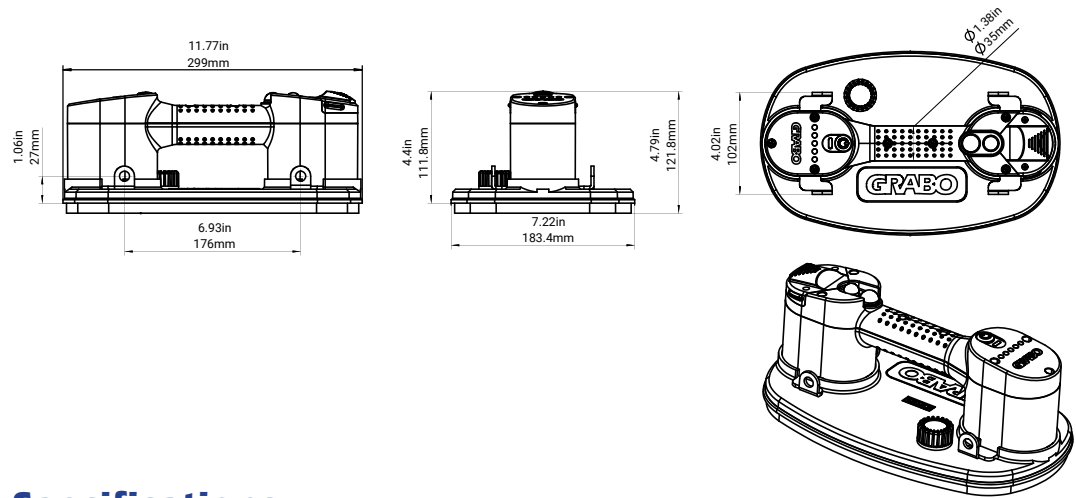

### Specifications:

Model/SKU	GRABO V2 / GV2-1B-FB-1S
Battery	14.8VDC 2600mAh Li-ion
Rated Power	16W
Charger Input Voltage	100-240VAC 50/60Hz
Battery Charging Time	~2hrs
Non-Stop Running Time (Full Charge)	1.5hrs
Running Cycles (On Full Charge)	900 ON-OFF cycles of 10 seconds
Stand-by Mode (Charge Hold)	30 days
Pump Service Life	100000+ ON-OFF cycles / 800+ hrs continuous
Rated Air Flow	0.7cfm ( 20 L/min )
Maximum Vacuum Rate	11.6Psi ( 0.8 Bar, 80 kPa )
Maximum Lifting Capacity	375Lbs ( 170 kg )
L x W x H	11.77 x 7.22 x 4.79" ( 299 x 184 x 122 mm )
Net Weight (With Battery)	3.3Lbs ( 1.54 kg )
Working Temperature	32°F~140°F ( 0°~60 °C )
Applicable Surface Type	Peak/valley heights less than 0.1" ( 3mm )

### Lifting Capacity:

Material	Glass	Ceramic Tiles	Metal	Plastic	Wood	Rough Slate	Rough Concrete	Dry Wall
Direction								
Perpendicular 	375Lbs ( 170 kg )	375Lbs ( 170 kg )	242Lbs ( 110 kg )	220Lbs ( 100 kg )	220Lbs ( 100 kg )	176Lbs ( 80 kg )	176Lbs ( 80 kg )	165Lbs ( 75 kg )
Parallel Hold 	265Lbs ( 120 kg )	265Lbs ( 120 kg )	242Lbs ( 110 kg )	220Lbs ( 100 kg )	143Lbs ( 65 kg )	176Lbs ( 80 kg )	176Lbs ( 80 kg )	143Lbs ( 65 kg )

Based on product information at time of publication. Environmental conditions can affect product performance and longevity; consult the product manual on GRABO.com or contact a Sales Representative for more information.

NOTICE: Due to the high pressure that is created with the Nemo GRABO® we strongly recommend that you do not attempt to attach the Nemo GRABO® to glass thinner than 6mm thick. Damage can occur to glass that is thinner than 6mm thick.

**By Nemo Power Tools**  
[www.GRABO.com](http://www.GRABO.com)

#### GRABO headquarters:

Eastern Commerce Center  
6000 S Eastern Ave  
Unit 9E  
Las Vegas, Nevada, 89119

Info@GRABO.com  
www.GRABO.com

**Main Office:**  
+1 (844) 430-0510

**Help & Warranty:**  
+1 (702) 718-2433